



Fish Tales Newsletter

Sheboygan Area Great Lakes Sport Fishermen
PO Box 982, Sheboygan, WI 53082
920-452-9660

SAGLSF Newsletter Fall 2004

Pro Troll is coming!

For our November meeting we have a very special treat. A representative from Pro Troll, makers of flashers, lures, and of course the original black box will be on hand to discuss their products. Pro Troll is the inventor of the eChip, a way to generate positive ions with a small device mounted on lures and flashers. From their website: "This device promises to revolutionize fishing with artificial baits and lures. Its electric nerve discharge gives life to the lure. As predators approach they can sense the nerve discharges and will attack much more often." Come and find out how to put this new technology to use in your fish catching arsenal. For more information on Pro Troll visit www.protroll.com.



Swim with the Fishes

To start off the New Year, Steve Radner has agreed to join us for our January meeting. Many of you probably already know Steve; he is one of the infamous Lake Michigan divers. Steve will be talking about the recently discovered "mystery wreck" off the port of Sheboygan in approximately 200 feet of water; he'll discuss the Haddie and the Chamblain as well. Steve plans on showing a video and has quite a few pictures to share. This is an outstanding opportunity to find out what it really looks like at the bottom of our beloved lake and also to learn some more about the wrecks found around our homeport.



A very happy angler shows off her catch at this year's inaugural Junior Coho Derby.

In This Issue

Pro Troll is Coming, Swim with the Fishes, 2005 Calendar, Get the Gear, Natural Resource Careers Camp, Ozaukee / Sheboygan Inter-Club Contest, 2004 Big Fish Board, Big Brother and Sisters, Coho Derby, Make Your Own Double Planner Boards, Cookbook



President's Report

I feel we had a short summer this year. It came late with lots of rain this fall.

But, our club had lots of activities. The Swap meet the end of March did well this year. Next year Don

Baumann has moved it to April 9th.

We held two Brat Fries, one in April at the pig on Talor Dr. and one at the Wharf in August. Next we will try one on July 2 at the Wharf. The Kids Derby was a success in June. The Wharf also had a good turn out for the Coho Derby even thou the sea's were quite high. They donated \$4000.00 of the proceeds to our club! How about that?

The Big Brother's & Sister's outing went very good. Troy Burmesch did a super job of handling that.

Scott and Ken did a real Good job on the Sheboygan / Ozaukee Fish Contest. We won the trophy by a very very close margin.

The Family Contest went well with a lot of participation. Thanks to Jim Gruber & Paul Voss & their helpers. We do not have a December meeting so I wish you all a Safe and Happy Holliday's

I hope to see you all Next year!

**Your Club President,
Lyle E. Peschke**

Meeting Reminder

Monthly membership meetings are held the 3rd Tuesday of every month at 7PM at the Outboard Club, 732 North Water Street. Also, don't forget, there will be no meeting in December because of the holidays.

Mark Your Calendars

This year's Annual Awards Banquet will be held on February 12 at our traditional stomping ground, the Wagon Wheel in Howards Grove. Look for more information to arrive after the holidays.

Get the Gear

The unofficial motto of our club is "A Good Club, On a Great Lake!" Now you can get the gear to show the world. That's right; t-shirts are now available, just head on down to the Wharf and pick up one. Makes a great gift. You can also get jackets made with our logo and insignia. Contact Scott Wunsch (920-457-7358) for more details. 📞

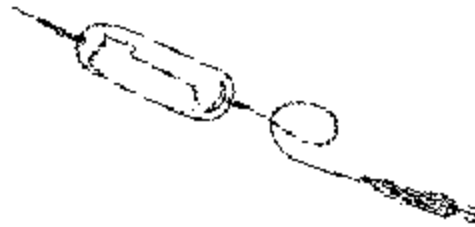

Board of Directors

The following are the 2004 Board of Directors and contact numbers

President

Lyle Peschke
920-452-9660
Leddie76@aol.com

Alternate Secretary

Ken Mueller
920-457-3824
skidog@bytehead.com

Speaker Coordinator

Russ Kleinert
troller2@charter.net

Vice President

James Schlegel
920-918-2628
schled@nconnect.net

Membership Secretary

(sharing position)
Jeff & Grace Brown
920-458-4406
riverfrontdrive@yahoo.com

Newsletter

Dave Dortman
920-451-7053
ddortman@yahoo.com

Treasurer

Larry Freitag
920-458-4117
lfreitag@excel.net

Board Member

Don Baumann
920-457-4995

Sheboygan Area Great Lakes Sport Fishermen

PO Box 982
Sheboygan, WI 53082
920-452-9660

Secretary

Jennifer Cihak
920-452-9660

Board Member

Scott Wunsch
920-457-7358
fishhead@excel.net

Board of Directors Meetings

Our monthly Board of Directors Meetings are always held the second Tuesday of the month at the Sheboygan Outboard Club. Members are always welcome and encouraged to attend. If interested in joining the board or sponsoring one of the many activities, please contact a current board member. Requirements for joining the boards are club membership for at least one year and a genuine desire to protect this resource for future generations. Sign up now and participate.

Treasures Report

Our books are always open for inspection at the monthly meetings for all club member to review. Larry Freitag, our treasurer, announces our clubs balances at each monthly meeting.

SAGLSF CALENDAR 2005

The club is involved in a number of activities this year. The following is a list of events and the club volunteer members who are responsible. Mark your calendars now and plan to participate.

Awards Banquet

February 12, 2005

Wagon Wheel in Howards Grove

SAGLSF Swap Meet

April 9, 2005

Don Bauman

South High School Cafeteria

Sheboygan's Big Fish Board 2005

January 1, 2005, to December 31, 2005

Jim Schlegel

Register at the Wharf

Club Fishing Contest

May 30, 2005, to September 5, 2005

Ed Kalmerton, sign up at the Wharf

Junior Coho Derby

June 25, 2005

Sponsored by the Wharf

Big Brothers Outing

July 9, 2005

Troy Burmesch

Powder Puff Derby

July 20, 2005

Sponsored by the Wharf

Ozaukee / Sheboygan Inter-Club Fishing Contest

July 10, 2005

Port Washington

Scott Wunsch & Ken Mueller

Family Contest

To Be Determined

Paul Voss and Jim Gruber

Coho Derby

August 13 & 14, 2005

Sponsored by the Wharf

Natural Resource Careers Camp

Once again this year our club sent three students to the Natural Resource Careers Camp and the Outboard Club send two students. Char Nelson, Elaine Wunsch, and Brian Hoffman interviewed and selected three boys and two girls to attend the camp. Attending the camp, which was held July 25–30, was Todd Batina, Sam Christel, Danielle Christel, Mitchell Brachmann, and Kari Keller. During our October meeting several of the students stopped by to thank the club and give us an update on what they had learned. All agreed that it was a truly worthwhile experience; highlights included camping out, learning to test water quality, and helping the students decide whether a career in natural resources was right for them. This is one of the many worthwhile activities that your membership in the SAGLSF promotes. Following is official write-up on the camp:

“Natural Resource Careers Camp – This camp is a Central Wisconsin Environmental Station tradition. Whether you’re thinking about becoming a wildlife researcher, game warden, forester, or park ranger, you’ll get the inside scoop here. We’ll help you discover tremendous opportunities that exist in the fields of forestry, waters, wildlife, land use planning, soils, and environmental education/interpretation. You’ll also get to meet professionals who work in a variety of natural resource specialties. We’ll show you around the UW-Stevens Point College of Natural Resources to see what a world class natural resource program is all about. Having guided teen through our natural resource careers camp for more than 26 years, let us help you make the best decision for your future.”

2004 Inter-Club Fishing Contest Results

Sheboygan:

Total Points:	1552.54	
Total Boats:	12	
Average points per boat:	129.37	(winner)

Ozaukee:

Total Points:	408
Total Boats:	5
Average points per boat:	81.76

Top Boats:

Salmonator (Sheboygan)	234.6 points
Jacks or Better (Sheboygan)	214.3 points

1st Place Men:

22.5 lbs (King)	Don Beck	Moby Don (Sheboygan)
-----------------	----------	----------------------

2nd Place Men:

19.5 lbs (King)	Mark Parisek	Salmonator (Sheboygan)
-----------------	--------------	------------------------

1st Place Ladies:

17.2 lbs (King)	Heather Rach	Salmonator (Sheboygan)
-----------------	--------------	------------------------

2nd Place Ladies

15.3 lbs (King)	Jean Effa	Nauty Lady (Sheboygan)
-----------------	-----------	------------------------

1st Place Junior

15.8 lbs (King)	Justin Wakefield	Captain Shook (Sheboygan)
-----------------	------------------	---------------------------

This year’s inter-club derby was held on our home water, and the results definitely showed. But get ready for next year, we travel to Port Washington. Mark your calendars now so we make a good showing.

SAGLSF Big Fish Board 2004

The “Sheboygan Big Fish Board 2003,” sponsored by the Sheboygan Area Great Lakes Sport Fishermen Club is officially over. This years winners are as follows:

Chinook Salmon	26.76 lbs.	7/03/04	Jamie Dickrell	Sea Dog
Coho Salmon	20.50 lbs.	9/26/04	Tim Schweitzer	Sorry Charlie
Rainbow Trout	17.40 lbs.	7/15/04	G. Werner	Sorry Charlie
Lake Trout	23.18 lbs.	7/26/04	Jim Vercouteren	Sea Dog
Brown Trout	20.98 lbs.	7/21/04	Jeannie Genske	The Duke

The Sheboygan Great Lakes club would like to thank all those who participated, and would like to congratulate all of this year’s trophy winners. Awards will be handed out at the annual banquet on February 5, 2005. All entries must be officially weighted at the Wharf. Standings Board is posted at the Wharf and can be found on the web at www.fishsheboygan.com, click on fishing reports.

Big Brothers – Big Sisters By Jim Baumgart

BIG BROTHERS - BIG SISTERS were out on Lake Michigan fishing on Saturday morning, July 10. They were the guests of the Sheboygan Area Great Lakes Fishermen; it was the 25th year the club hosted the event.

First of all, the fish were biting. Captain Brian Gruenke took Big Brother Mark Schuessler and his Little Brother Dylan of Sheboygan Falls. It was Dylan’s third trip in as many years and he met face to face with a hart fighting ten-pound rainbow trout and won. Seven fish were boated. Jamie Martain and his dad, Jim (got him out of retirement for the trip), were on their boat “Widetrack” and had a great time with Big Sister Kari Beyersdorf and her Little Sister Blaze of Sheboygan Falls. They boated 13 fish including a 13 pound king salmon caught by Blaze, the largest fish of the trip. Blaze was able to catch her limit

Big Brother Richard McDonald had his Little Brother, Brandon, of Plymouth on the boat “Moby Don”. Brandon took charge by bringing in two five-pound fish; a Coho and king salmon.

Big Sister Connie Guttenberg was fishing alongside her ten year old Little Sister, Samantha of Sheboygan. Sam, as she likes to be called,

was fishing on the boat “Greateoz”. Fighting and catching a 17.5-pound king salmon seem hard for Sam but she was up to the battle; she also caught a nice 11 pound king. Big Brother Jim Jagler had a pair of 12-year old twins, Little Brothers Jesse and Jordan of Sheboygan. They were fishing the boat “Hollandaze” and boated a 3.6 pound lake trout and two king salmon weighing in at 17 and 9.9 pounds. Troy Burmesch of the Sheboygan Area Great Lakes Sports Fishermen and Paul Hertel of Big Brothers and Big Sisters were in charge of the outing. Martin Pontiac of Sheboygan provided the picnic food and trophy’s for the gathering at the end of the trip. Some of the club members were at hand to set up the food. The Wharf, located along the Sheboygan riverfront, volunteered to clean and bag the fish.

John Repphun, Dick Schulz, Jamie and Jim Martin, Brian Gruenke, John Alexander, Don Beeck, Jim Gruber, John Vertacic and Don Bauman made up the volunteer boat crews. It was a great day for fishing and an outstanding experience for the Little Brothers and Little Sisters. Troy Burmesch and Paul Hertel thanked to all who made the trip possible. Hertel presented a 25 Anniversary Plaque to Lyle Peschke, president of the Sheboygan Area Great Lakes Sports Fishermen, for the club’s service to youth.



Pictured (left to right) Lyle Peschke, Troy Burmesch, and Paul Hertel of Big Brothers and Sisters of Sheboygan.

Honesty provides 2004 Coho Derby winner by Steve Ottman

SHEBOYGAN—It was an eventful weekend (August 28-29) that dealt Coho Derby officials with a mixed bag of weather problems that gave many fishermen all they could handle, but what happened at the end of the derby on Sunday was an admission you don't hear too often.

Grand Prize-winner, Mark Debbink of Sheboygan Falls registered a 10.80 lb. coho salmon and was told it was a first place fish according to the DNR officials at the weigh-in station.

When he arrived at the Wharf, Debbink looked at the leader board and saw that there was another larger fish caught by Matt Stephan in first. Debbink asked derby officials for an explanation.

Derby officials were ready to award the grand prize when Stephan came forward and explained that he didn't catch an 11.5 lb. fish. Through a clerical error his fish weighed only 8.5 lbs.

His honesty rewarded Debbink with a grand prize of a 14 ft. Smoker Craft Voyager Boat with a 25 horse Mercury Outboard donated by Thomson Marine of Sheboygan.

Debbink was fishing with friends on the "Chappy II" captained by Troy Giese. They were listening to the fishing update on the radio—figuring they wouldn't any prize-winning fish.

"About 12:30 we landed a fish that we thought was a brown trout at first because of the hooked mouth. We later determined it was a coho," said Debbink. "It was a big fish, so when we weighed it we inquired if there was anything bigger. DNR officials confirmed it would be in first place."

He didn't want any controversy, but Stephan's honesty cleared up what turns up to be quite a fish story. Derby officials rewarded Stephan with a rod and reel combo for coming forward.

The first place winners of the five fish categories were all eligible to win the grand prize. Coho salmon was picked for the grand prizewinner.

A cold and windy day greeted fisherman early Saturday morning. Winds out of the north made the waters of Lake Michigan rougher as day went on. By 9:00 am many of the coho derby entrants made their way in exhausted from fighting the waves.

About 430 fish were registered, with many of them caught before the weather took a turn for the worse.

Sunday the winds calmed down, but a passing weather front scattered the fish and produced 439 fish for a total of 869 fish in the two-day event—a combined weight of 7,794.47 lbs.

"We're tired, but happy with the results. Sunday turned out to be great day to fish," said Jeff Brown of the Wharf.

Numbers of fish were down compared with 2209 fish in 2003, but the number of entrants increased from 800 to 830.

This years Super Derby attracted 51 boats—five more than last year. A great competition between Hi-Tech, Sorry Charlie, and Happy Hooker highlighted the two-day derby. Less than 10 pounds of fish separated these boats from first to third.

Hi-Tech captain Bryan Gruenke and his crew registered 175.26 lbs. of fish to win the \$3,000 first place prize. "The weather was rough. It's a good time of year to fish. Most of the fish gather around the harbor. We had a good time," said Gruenke. "Sorry Charlie and I are good friends, we call each other and let each other know where the fish are, and it was a friendly competition." Sorry Charlie took second, with Happy Hooker taking third.

Fifty-eight-year old, Sara Brion of Howards Grove, a grandmother of 20 children, landed a 23.72 chinook salmon for the largest fish of the tourney.

Jeff and Grace Brown of the Wharf would like to give special thanks to the main sponsors, Thomson Marine, Sheboygan Chevrolet, Torke Coffee, Priority Sign, and Genuine Mechanics. Proceeds from the derby were donated help children at Camp Y-Koda. This year the Wharf donated \$10,000 to Camp Y-Koda, \$4,000 to the SAGLSF Club, and \$1,000 was earmarked for next year's Junior Coho Derby.

Double Planer Boards

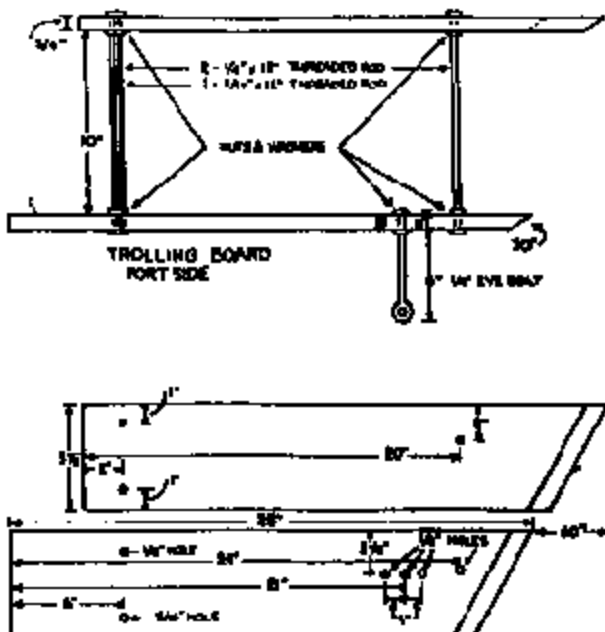

MATERIALS REQUIRED PER BOARD

2 pcs	1"X6"X28"	Redwood
2 pcs	12"X1/4"	Threaded Rod
1 pc	12"X5/16"	Threaded Rod
1 pc	1/4"X6"	Eye Bolt
10 pcs	1/4"	Flat Washers
10 pcs	1/4"	Hex Nuts
4 pcs	5/16"	Flat Washers
4 pcs	5/16"	Hex Nuts

In addition to the materials above you will need wood saw a rasp (to form the 30 degree angle on the face) a couple of wrenches to fit the hex nuts and some wood sealant. Paint your new planer boards a bright highly visible color such as Federal Safety Orange preferably fluorescent! (Remember your fellow fisherman and make the boards easy for them to see!) You will also need some cord or extra heavy duty monofilament line for a tether line.

When making your planer boards keep in mind that the pattern shown here is for a left hand planer board and the pattern will have to be reversed for the right hand board. The center hole is the best place to locate the eye bolt when starting out (move eye rearward to make the board pull out harder). The 5/16" threaded rod must be located on the bottom as shown, it acts as a counter weight and keel to keep the boards upright in the water.

SAGLSF Cookbook



Pickled Fish

Complements of Jim Gruber,
a.k.a The Great Oz

Fish (salmon or other favorite Great Lakes fish)
5/8 cup canning salt per quart of fish
White vinegar
White sweet onion slices

Brine:

1 cup sugar
1 cup vinegar
½ cup port wine
¼ box pickling spice

Skin and chunk fish. Measure fish in a quart jar and place in a large container. Add 5/8 cup salt for every quart of fish. Add enough white vinegar to the container to cover fish. Stir. Cover with container lid and refrigerator for a total of 6 days. On the third day shake or stir the fish and place back in refrigerator.

After 6 days, drain and rinse fish with cold water until water runs clear. Let stand 1 hour and drain again.

Pack fish in sterilized canning jars with alternating layers of fish and white sweet onion slices. Leave ½" head space.

Prepare brine by heating brine ingredients until sugar is dissolved. Do not boil. Cool well. This makes enough brine for 3 - 4 quarts of fish. Increase brine according for how many quarts of fish you are making.

Pour cooled brine over fish and onions. Use a butter knife to make room for brine to get to the bottom of the jars. Cover with lids and rings and refrigerate for two weeks. After two weeks, enjoy with crackers or your favorite accompaniment.

Cookbook Update

While working on the cookbook this summer I had the privilege of reading through a treasure trove of old SAGLSF magazines. For those of you remember, they were called the *Sheboygan Angler* and published almost annually as the club's main fundraiser. The books are a treasure trove of history and fishing knowledge. Of course I couldn't resist reviving a few items and presenting them to you in this newsletter. On page 5 you'll find instructions for making your own double planner boards, a style of fishing that is really coming back due to the clear water conditions in the Great Lakes. Not to mention, I'm always looking for winter projects.

Our new Fish Tales Boat that appears on the newsletter outer wrap was also borrowed from a classic SAGLSF magazine. I have, however, changed the name of the boat. Do you know what the name was? Care to take a guess? The first person to email me the correct answer at ddortman@yahoo.com will receive a FREE copy of the cookbook once it is published. Sorry, board members and committee chairs are not eligible.

This month's recipe comes from Jim Gruber who is always bragging about how good his wife's pickled fish is. Jim, I'm still waiting for my sample jar. Finally, the cookbook is almost complete and will go to press after the holidays to be printed in plenty of time for our swap meet in April. But we could still squeeze in a few more sponsors, see ad below. I hope everyone had a great season.

See you on the water!

Dave Dortman

Sponsors Needed!

Now is the time to lend your support and sponsorship to the SAGLSF Cookbook. Many members and local business have stepped up and donated generously, but we still need more. Remember, you don't have to be a member to advertise—so tell your family, friends, and colleagues!

“How much does it cost?” you ask. That's the best part! It's **only \$25** for a business card size ad. Where else are you going to get this quality of advertising at this price?

If you or your business have not yet committed to taking an ad, please consider doing so now.

For more information, contact Dave Dortman at
(920) 451-7053 or ddortman@yahoo.com

SAGLSF MEMBERSHIP APPLICATION

Sheboygan Area Great Lakes Sport Fishermen
P.O. Box 982
Sheboygan, WI 53082



Annual Dues

Family - (husband, wife, two or more children)-----	👤	\$30.00
Husband & Wife-----	👤	\$25.00
Individual-----	👤	\$20.00
65 or Older (Individual or Husband & Wife)-----	👤	\$15.00
Junior-----	👤	\$5.00
New Member (Initiation Fee)-----	👤	\$5.00

Member Name _____ Spouse's Name _____

Family's Name _____ Family's Name _____

Street Address _____ City _____ State _____ Zip _____

Occupation _____ Radio FM/CB _____ Call Letters _____

Boat Name _____ E-mail _____

Telephone _____

Unless otherwise noted, the SAGLSF general membership meetings are always held the third Tuesday of the month starting at 7:00 PM at the Sheboygan Outboard Club. Meetings are every month of the year except the months of July and August. The public and guests are always welcome and encouraged to attend these meetings. The board of directors meets every second Tuesday of the month all year round at the same time and location. Any member of the SAGLSF is welcome to attend a board meeting. Any comments and concerns are welcome. For the latest newsletter and membership information, send a self addressed letter to the address above.

Our clubs purpose is as follows:

- 1.) To unite individuals interested in sport fishing in the Great Lakes.
- 2.) To promote educational programs in sport fishing and water safety.
- 3.) To exchange fishing information.
- 4.) To advance the quality of Great Lakes fishing and to assure pure fishing water, specifically in the Sheboygan area.

Join Today! Call 920-452-9660

ADDRESS
CORRECTION
REQUESTED

PO Box 982
Sheboygan, WI 53082



CONTAINS DATED MATERIAL

Fish Tales Newsletter

